



C127 - COLOUR DISPLAY LOGGER



The C127 comes standard as a combined 7" full colour display and powerful control device with outstanding readability in direct sunlight. With the addition of the Data Logging upgrade it becomes a fully programmable data logger with 120 MB memory. Optional USB Logging provides additional data capacity and flexibility.

Numerous supplied display layouts offer fixed graphics with configurable channels and labels, while the optional Display Creator software provides the tools for full screen customisation.

The C127 acquires data from other devices, such as an ECU, and can display data channels, warning alarms, lap times, fuel calculations, minimum corner speeds, maximum straight speeds and much more. It can also display live video on screen.

► FEATURES

- High resolution 178 mm (7" approx) colour LCD display
- High brightness for sunlight readability
- Optional internal logging and USB logging'
- 16 full colour (RGB) LEDs; colour, function and intensity are fully programmable
- Suitable for bikes, cars, marine and industrial applications
- Supports Wideband Lambda from MoTeC PLMs or LTCs
- Easily integrates with MoTeC CAN based devices such as ECUs and expanders. Full I/O expansion with E888 and E816.

- GPS Lap Timing
- Supports T2 Telemetry (optional)
- Composite video input allows for live on-screen footage, for example from a rear view camera (requires Display Creator).

► ACCESSORIES

- 62204: C127 LOOM
- 61279: CABLE - USB A PANEL TO MINI B
(This cable is required for USB Logging)
- 61280: MOTEC 32 GB DATA PLUG
- 61292: KINGSTON 32 GB USB3 FLASH DRIVE

► OPTIONAL UPGRADES

- 29800: C127 I/O
- 29818: C127 120 MB LOGGING
- 29814: C127 USB LOGGING
- 29816: C127 DISPLAY CREATOR
- 29820: C127 PRO ANALYSIS
- 29823: C127 T2 TELEMETRY

► SPECIFICATIONS

Display

- Type: Colour TFT LCD, anti-reflective
- Resolution: 800 x 480, anti-aliased graphics
- Layouts: Selectable fixed layouts (user programmable layouts via optional Display Creator software)
- 48 user-defined, scrollable message lines with programmable overrides
- 3 programmable modes with customisable labels

Logging Options (upgrades required)

- 120 MB internal logging memory, fast Ethernet download
- Optional USB logging to a removable storage device (internal logging required as a prerequisite)
- Logging rates up to 500 samples per second
- i2 Standard data analysis software included (Pro Analysis upgrade available)

Removable USB Storage Device Options

- Kingston 32 GB USB3 Flash Drive – fast, low weight and low cost, not mechanically latched or waterproof.
- MoTeC 32 GB USB3 Data Plug – mechanically latched, waterproof with anodised housing, ideal for exposure to the elements and vibration.

Alternative USB storage devices may be used but are not recommended.

Inputs

- 2 x Digital and 3 x Speed inputs
- 1 x Composite video input

Inputs - optional (requires I/O upgrade)

- 6 x Analogue voltage inputs
 - 4 x 0 to 5.46 V, 1.33 mV resolution
 - 2 x 0 to 15.0 V, 3.66 mV resolution
- 2 x Analogue temperature inputs
 - 0 to 15 V, 3.66 mV resolution

Outputs - optional (requires I/O upgrade)

- 4 x low side outputs PWM or switched operation
- 0.5 Amp max, current limited, thermal overload protected

Expanders

The C127 is fully compatible with E816 and E888 expanders.

Internal Sensors

- 3-axis accelerometer, detection range: +/- 5G
- Dash temperature sensor
- Sensor supply voltage
- Battery voltage

Communications

- 2 x configurable CAN buses, with individually programmable CAN bus speeds. One can be used as RS232 Receive.
- 2 x RS232 ports, one with transmit and receive, one with receive only.

Power Supply

- Operating voltage: 6 to 32 V DC

- Operating current: 0.8 A typical at 14 V (excluding sensor currents)
- Reverse battery protection
- Battery transient protection

Sensor Supply Currents

- 5 V sensor supply: 0.25 A maximum
- 8 V sensor supply: 0.25 A maximum

Operating Temperature

- Internal: -20°C to 80°C (above 60°C maximum backlight brightness progressively reduced)
- Typical ambient temperature range in free air: -20 °C to 60 °C

Ingress Protection (IP) Rating

- IP67 dust tight, protected against water immersion (up to 30 minute submersion to a depth of at least 15cm)

⇒ IP rating is dependent upon the user ensuring that the connector entries are waterproof, which, as a minimum, requires all unused wire cavities on the connector to be plugged.

Physical

- Size: 196.2 x 122.5 x 24.9 mm excluding connectors
- Weight 630 g
- 1 x 34 pin waterproof connector
- 1 x mini USB port (located on the back of the device)

▶ SCREEN CLEANING

Wipe using a clean water-dampened microfibre cloth, followed by a clean, dry microfibre cloth.

▶ COMPATIBILITY

- MoTeC ECUs: All (some earlier models may require an additional adaptor in conjunction with the RS232 adaptor)
- MoTeC Displays/Loggers: All
- MoTeC Accessories: E816, E888, SLM, PLM, LTC, BR2, PDM, GPS, VCS etc.
- Many non-MoTeC devices

▶ SOFTWARE

Windows-based Dash Manager for setup and management of the display and data logging system, that provides:

- Configuration of the inputs, outputs, LEDs, display, data logging and calculations

► **ETHERNET WIRING**

- Offline generation of a configuration file that can then be sent to the device.
- Channel monitoring
- Firmware updating and extensive help screens

Optional Display Creator software allows for full customisation of the screen layout, including live video.

i2 Data Analysis software (Standard or optional Pro) provides the tools for comprehensive data analysis.

Ethernet Connector		MoTeC Loom Colour	C127	
Pin	Function		Pin	Function
1	Ethernet TX +	Orange/White	11	Ethernet RX +
2	Ethernet TX -	Orange	10	Ethernet RX -
3	Ethernet RX +	Green/White	2	Ethernet TX +
6	Ethernet RX -	Green	1	Ethernet TX -

⇒ The wiring specified is the preferred cross-over configuration. However, the wiring can also be configured as straight-through. Cat 5 Ethernet cable must be used.

Pin Numbering

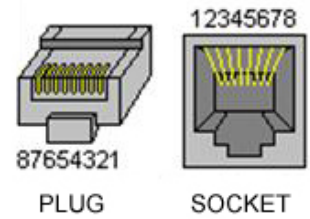

► **ECU WIRING**

When using an M4, M48 or M8 ECU, the C127 should be connected via RS232. For some ECUs, a PCI cable may also be required.

The Display Logger should be connected via the CAN bus when using an M1 or 'Hundred Series' ECU (M400/M600/M800/M880) or M84, and any number of other CAN devices.

Example:

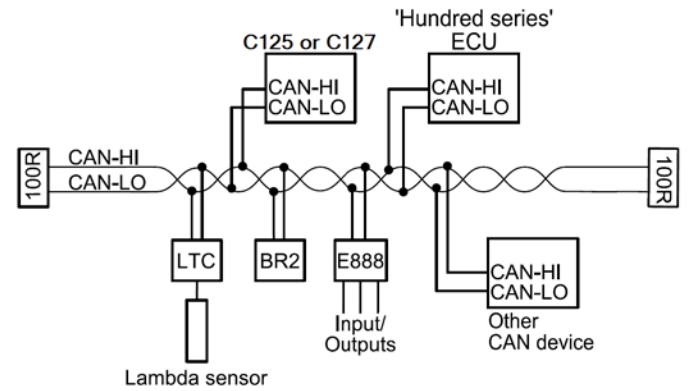

Detailed wiring information is available in the user manual at www.motec.com/downloads.

► **DIMENSIONS AND MOUNTING**

Measurements in mm.

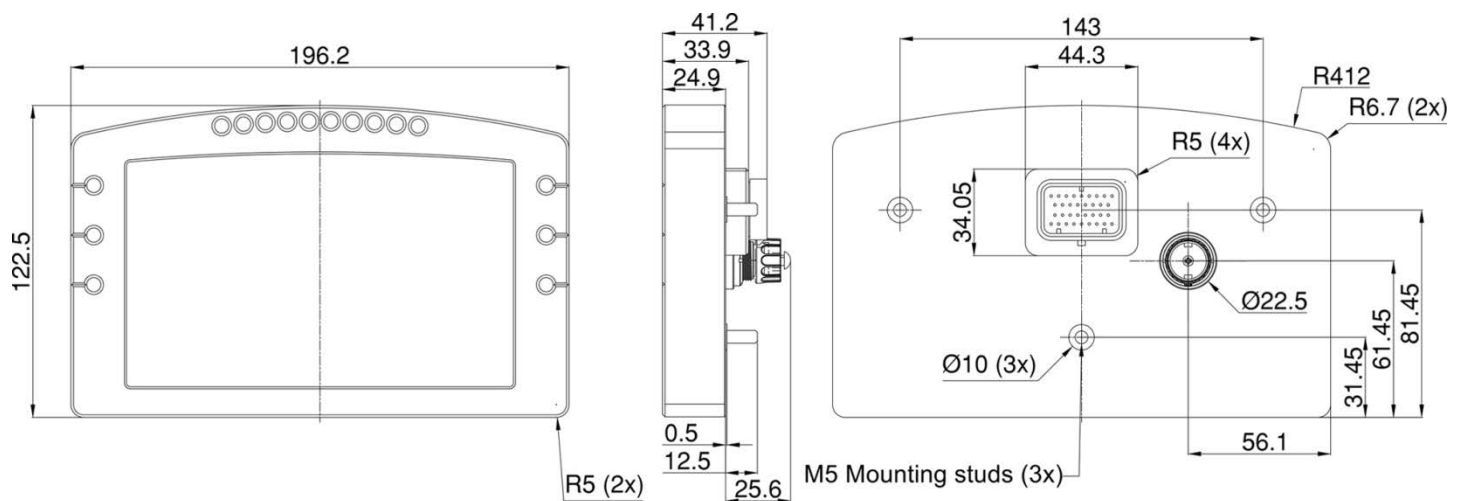

⇒ **Note:** Do not remove any part of the casing. The case provides electromagnetic screening to avoid interference with other equipment, and is also essential for thermal management. Thermal management may be compromised if mounted in a confined space, refer to the operating specifications.

Ensure product is not stressed when mounted.

▶ PINOUT

Mating Connector: Part number 65044

Pin	Name	Standard Function	Optional Function (12 I/O upgrade #29800)
1	E-TX-	Ethernet Transmit -	
2	E-TX+	Ethernet Transmit +	
3	AV1		Analogue Voltage Input 1
4	AV2		Analogue Voltage Input 2
5	AV3		Analogue Voltage Input 3
6	AV4		Analogue Voltage Input 4
7	8 V	Sensor 8 V	
8	5 V	Sensor 5 V	
9	0 V	Sensor 0 V	Video Ground
10	E-RX-	Ethernet Receive -	
11	E-RX+	Ethernet Receive +	
12	AV5		Analogue Voltage Input 5
13	AV6		Analogue Voltage Input 6
14	DIG1	Digital Input 1	
15	DIG2	Digital Input 2	
16	AT1		Analogue Temp Input 1
17	AT2		Analogue Temp Input 2
18	CAN1L	CAN1 Low	
19	CAN1H	CAN1 High	
20	RS232-1 TX	RS232-1 Transmit Output	
21	SPD1	Speed Input 1	
22	SPD2	Speed Input 2	
23	SPD3	Speed Input 3	
24	VID1		Video Input 1
25	RS232-2 RX	RS232-2 Receive Input	
26	CAN2L	CAN2 Low/RS232 Ground Input	
27	CAN2H	CAN2 High/RS232 Receive Input	
28	RS232-1 RX	RS232-1 Receive Input	
29	AUX1		Auxiliary Output 1
30	AUX2		Auxiliary Output 2
31	AUX3		Auxiliary Output 3
32	AUX4		Auxiliary Output 4
33	BAT+	Battery Positive	
34	BAT-	Battery Negative	