



## L120 - ENCLOSED LOGGER (USB)



The L120 Enclosed Logger (USB) is a powerful control device and fully programmable data logger, all in one compact unit.

It comes standard with 120 MB internal memory plus USB Logging for additional data capacity, convenience and flexibility.

The L120 acquires data from other devices, such as an ECU, for logging and telemetry. It can be used in a wide range of applications, either as a standalone unit or integrated with other electronic devices such as displays and PDMs.

**Note: An L120 Enclosed Logger without USB Logging is also available. (Part #18039)**

### ► FEATURES

- Suitable for bikes, cars, marine and industrial applications
- USB logging and internal logging
- GPS Lap Timing
- Supports T2 Telemetry (optional)
- Supports Wideband Lambda from MoTeC PLMs or LTCs
- Easily integrates with MoTeC CAN based devices, such as ECUs and expanders.
- Full Input/Output (I/O) expansion with E888 and E816

### ► ACCESSORIES

- 62206: L120 LOOM
- 61279: CABLE - USB A PANEL TO MINI B  
(Included, but also available as a replacement part)
- 61280: MOTEC 32 GB DATA PLUG
- 61292: KINGSTON 32 GB USB3 FLASH DRIVE

### ► OPTIONAL UPGRADES

- 29601: L120 I/O
- 29621: L120 PRO ANALYSIS
- 29624: L120 T2 TELEMETRY

### ► SPECIFICATIONS

#### Logging

- 120 MB internal logging memory
- USB logging to a removable storage device
- Logging rates up to 500 samples per second
- i2 Standard data analysis software included (Pro Analysis upgrade available)

## Removable USB Storage Device Options

- Kingston 32 GB USB3 Flash Drive – fast, low weight and low cost, not mechanically latched or waterproof.
- MoTeC 32 GB USB3 Data Plug – mechanically latched, waterproof with anodised housing, ideal for exposure to the elements and vibration.

Alternative USB storage devices may be used but are not recommended.

## Inputs

- 2 x Digital and 3 x Speed inputs
- 1 x Composite video input

## Inputs - optional (requires I/O upgrade)

- 6 x Analogue voltage inputs
  - 4 x 0 to 5.46 V, 1.33 mV resolution
  - 2 x 0 to 15.0 V, 3.66 mV resolution
- 2 x Analogue temperature inputs
  - 0 to 15 V, 3.66 mV resolution

## Outputs - optional (requires I/O upgrade)

- 4 x low side outputs PWM or switched operation
- 0.5 Amp max, current limited, thermal overload protected

## Expanders

The L120 is fully compatible with E816 and E888 expanders.

## Internal Sensors

- 3-axis accelerometer, detection range: +/- 5G
- Dash temperature sensor
- Sensor supply voltage
- Battery voltage

## Communications

- 2 x configurable CAN buses, with individually programmable CAN bus speeds. One can be used as RS232 Receive.
- 2 x RS232 ports, one with transmit and receive, one with receive only.

## Power Supply

- Operating voltage: 6 to 32 V DC
- Operating current: 0.4 A typical at 14 V (excluding sensor currents)
- Reverse battery protection
- Battery transient protection

## Sensor Supply Currents

- 5 V sensor supply: 0.25 A maximum
- 8 V sensor supply: 0.25 A maximum

## Operating Temperature

- Internal: -20°C to 80°C
- Typical ambient temperature range (free air): -20°C to 65°C

## Physical

- Size: 134.5 x 103.9 x 20.2 mm excluding connectors
- Weight 310 g
- 1 x 34 pin waterproof connector
- 1 x mini USB3 port (type B)

## ► COMPATIBILITY

---

- MoTeC ECUs: All models (some earlier models may require an additional adaptor in conjunction with the RS232 adaptor).
- MoTeC Displays/Loggers: All
- MoTeC Accessories: E816, E888, SLM, PLM, LTC, BR2, PDM, GPS, VCS etc.
- Many non-MoTeC devices

## ► SOFTWARE

---

Windows-based Manager software for device setup and management of the data logging system, providing:

- Configuration of the inputs, outputs, data logging and calculations
- Offline generation of a configuration file that can then be sent to the device.
- Channel monitoring
- Firmware updating and extensive help screens

i2 Data Analysis software (Standard or optional Pro) provides the tools for comprehensive data analysis.

► ETHERNET WIRING

Ethernet Connector		MoTeC Loom Colour	C125	
Pin	Function		Pin	Function
1	Ethernet TX +	Orange/White	11	Ethernet RX +
2	Ethernet TX -	Orange	10	Ethernet RX -
3	Ethernet RX +	Green/White	2	Ethernet TX +
6	Ethernet RX -	Green	1	Ethernet TX -

⇒ The wiring specified is the preferred cross-over configuration. However, the wiring can also be configured as straight-through. Cat 5 Ethernet cable must be used.

Pin Numbering

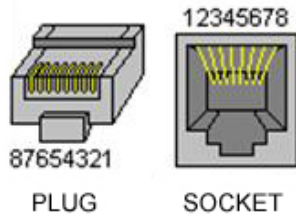

► ECU WIRING

When using an M4, M48 or M8 ECU, the L120 should be connected via RS232. For some ECUs, a PCI cable may also be required.

The Display Logger should be connected via the CAN bus when using an M1 or 'Hundred Series' ECU (M400/M600/M800/M880) or M84, and any number of other CAN devices.

Example:

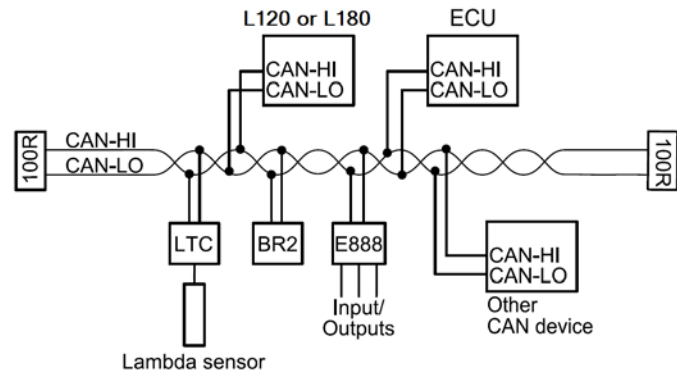

Detailed wiring information is available in the user manual at [www.motec.com/downloads](http://www.motec.com/downloads).

► DIMENSIONS AND MOUNTING

Measurements in mm.

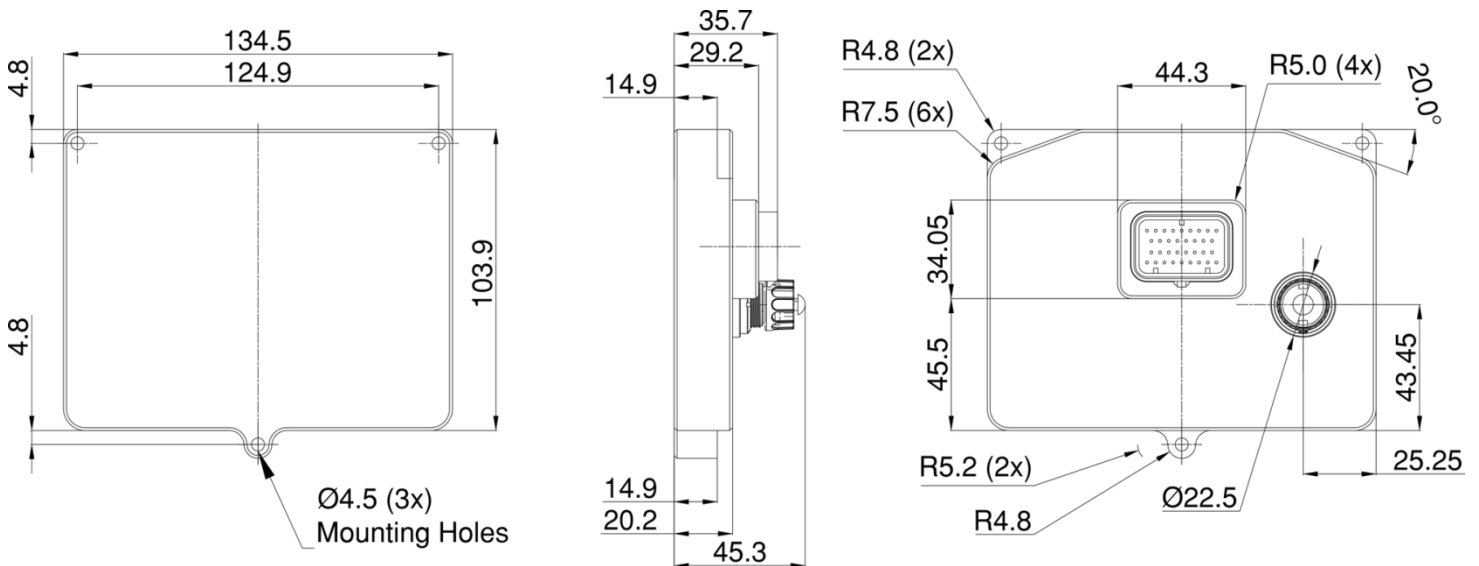

⇒ **Note:** Do not remove any part of the casing. The case provides electromagnetic screening to avoid interference with other equipment, and is also essential for thermal management. Thermal management may be compromised if mounted in a confined space, refer to the operating specifications. Ensure product is not stressed when mounted.

## ► PINOUT

Mating Connector: Part number 65044

Pin	Name	Standard Function	Optional Function (12 I/O upgrade #29601)
1	E-TX-	Ethernet Transmit -	
2	E-TX+	Ethernet Transmit +	
3	AV1		Analogue Voltage Input 1
4	AV2		Analogue Voltage Input 2
5	AV3		Analogue Voltage Input 3
6	AV4		Analogue Voltage Input 4
7	8 V	Sensor 8 V	
8	5 V	Sensor 5 V	
9	0 V	Sensor 0 V	
10	E-RX-	Ethernet Receive -	
11	E-RX+	Ethernet Receive +	
12	AV5		Analogue Voltage Input 5
13	AV6		Analogue Voltage Input 6
14	DIG1	Digital Input 1	
15	DIG2	Digital Input 2	
16	AT1		Analogue Temp Input 1
17	AT2		Analogue Temp Input 2
18	CAN1L	CAN1 Low	
19	CAN1H	CAN1 High	
20	RS232-1 TX	RS232-1 Transmit Output	
21	SPD1	Speed Input 1	
22	SPD2	Speed Input 2	
23	SPD3	Speed Input 3	
24	Not used	Not used	
25	RS232-2 RX	RS232-2 Receive Input	
26	CAN2L	CAN2 Low/RS232 Ground Input	
27	CAN2H	CAN2 High/RS232 Receive Input	
28	RS232-1 RX	RS232-1 Receive Input	
29	AUX1		Auxiliary Output 1
30	AUX2		Auxiliary Output 2
31	AUX3		Auxiliary Output 3
32	AUX4		Auxiliary Output 4
33	BAT+	Battery Positive	
34	BAT-	Battery Negative	